



eFlow[®]rapid

USER GUIDE FOR NEBULISED

ANTIBIOTICS

A step by step guide for patients
using the eFlow[®]rapid.



NEBULISER SELECTION

There are many PARI reusable nebulisers available for aerosol delivery of inhaled antibiotics, but this booklet deals solely with the eFlow[®]*rapid*.

This booklet acts as a supplement to, not replacement for, the Instructions For Use supplied with the eFlow[®]*rapid*.

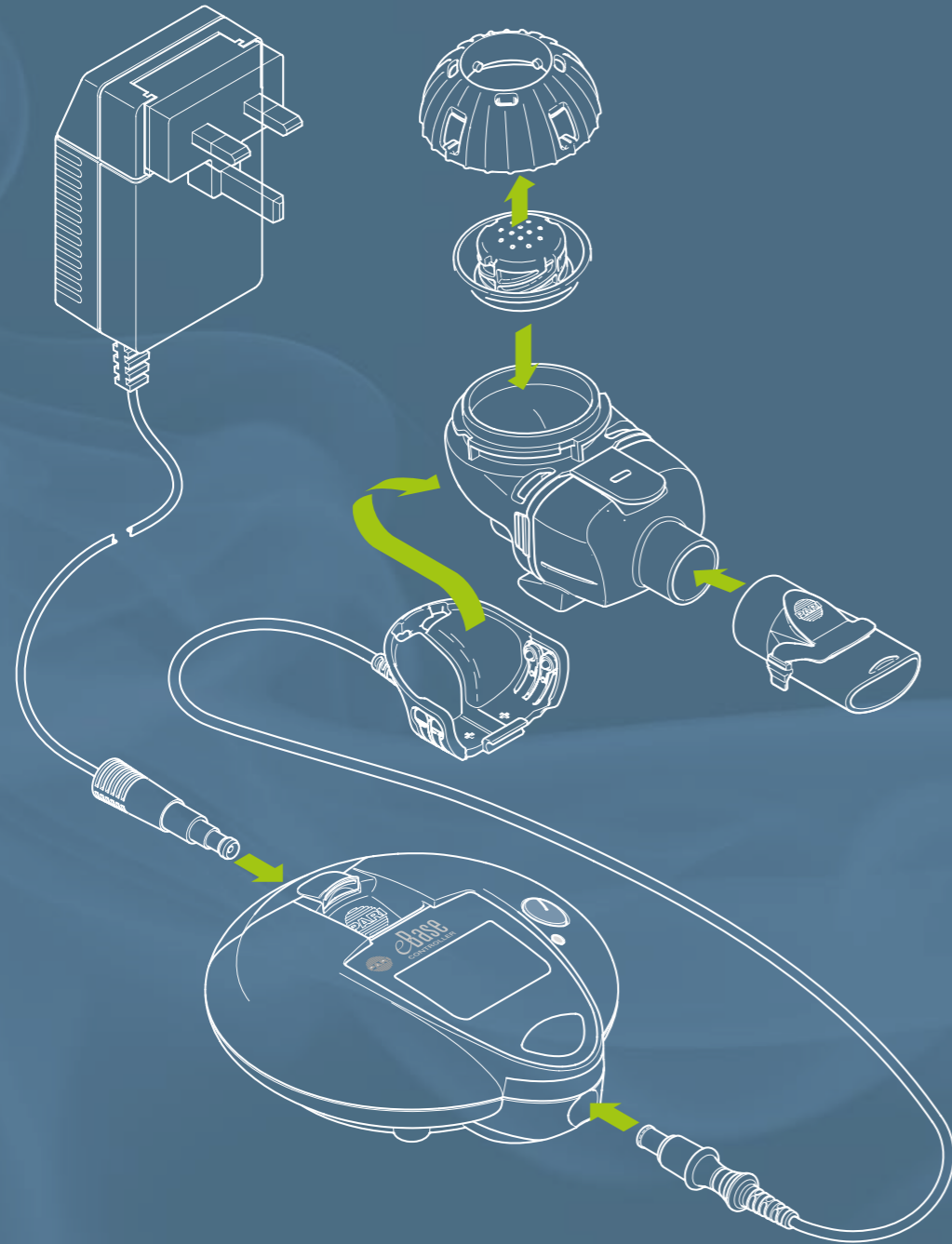

TABLE OF CONTENTS

Patient Contact	6
Aerosol Delivery of Inhaled Antibiotics	6
Supplies Checklist	7
Handwashing Technique	8
Aerosol Therapy Set-Up – Nebuliser with exhalation filter	10
Aerosol Treatment	12
Cleaning the Nebuliser	14
Disinfecting the Nebuliser	15
Easycare cleaning aid	16
Frequently Asked Questions	18

PATIENT CONTACT

▶ QUESTIONS ABOUT YOUR MEDICATION?

Call your healthcare professional

▶ QUESTIONS ABOUT YOUR PARI NEBULISER?

Call PARI Medical Ltd on 01932 341122, or the person who issued your nebuliser.

AEROSOL DELIVERY OF INHALED ANTIBIOTICS

Inhaled antibiotics can be delivered directly to the lungs using a medical device called a nebuliser system.

The eFlow[®]rapid nebuliser system consists of 2 primary components:

- eBase[®] controller which provides power and
- eFlow[®]rapid nebuliser handset which converts liquid medication into a fine aerosol that can be inhaled.



▲ This is the eFlow[®]rapid nebuliser system.

SUPPLIES CHECKLIST

You will need the following supplies for the aerosol treatment:

- Medication as prescribed by your healthcare professional
- 1 x nebuliser (as recommended by your healthcare professional)
- Optional: 1 x PARI Filter Valve Set. This exhalation filter protects family members and caregivers from inhaling medication particles from the treatment. It will also eliminate medication particles from depositing on clothing or furniture.
- Optional: BABY mask. Used as an attachment to PARI reusable nebuliser for delivery of medication to babies and young children.

You will need the following supplies for disinfecting the nebuliser:

DISINFECTING BY STEAM:

Electric baby bottle Steam Disinfector (non-microwave)

OR DISINFECTING BY BOILING:

A clean pan and supply of distilled water

Optional Accessories

PARI Filter Valve Set

Part No. 041G0500

Replacement Filter Pads

Part No. 041B0522 (pack of 30)

Part No. 041B0523 (pack of 100)

PARI BABY mask

Part No. 041G0700 size 0, Part No. 041G0701 size 1
Part No. 041G0702 size 2, Part No. 041G0703 size 3

The BABY mask is a soft silicon mask used as an attachment to PARI reusable nebulisers for delivery of medication to babies and young children who cannot use a mouth-piece. Use with BABY Bend when not using the Filter Valve set.



▲ PARI Filter Valve Set



▲ Replacement Filter Pads



▲ PARI BABY mask size 0 – 3

HANDWASHING TECHNIQUE

Hands should be washed prior to handling supplies and medications.



1

▲ Wet hands thoroughly with warm water.



2

▲ Use antibacterial soap if possible.

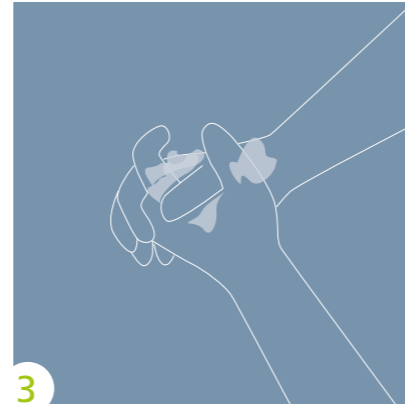

3

▲ Thoroughly wash hands for 1 – 2 minutes, covering the back and palm of each hand and between all fingers.

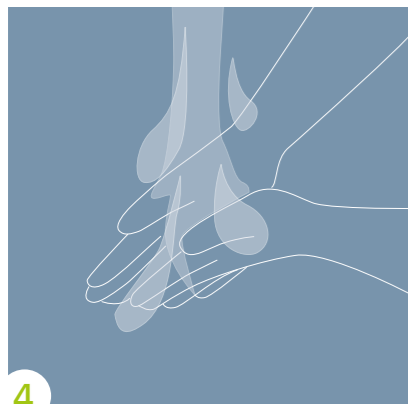

4

▲ Rinse hands thoroughly under running water.

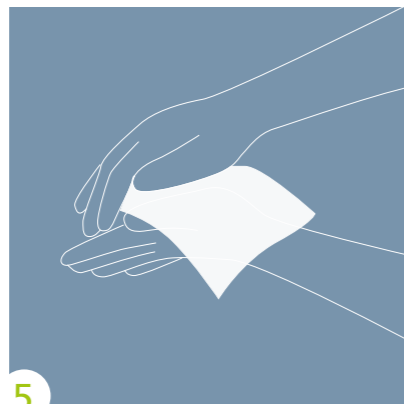

5

▲ Dry with a clean towel.

AEROSOL
THERAPY
SET-UP &
TREATMENT

AEROSOL THERAPY SET-UP – NEBULISER WITH EXHALATION FILTER

Preparing the nebuliser

1 Select a comfortable area in your home where your nebuliser can be placed on a stable surface and treatments can be taken without interruption.

2 Wash your hands using the correct hand washing technique (see page 8)

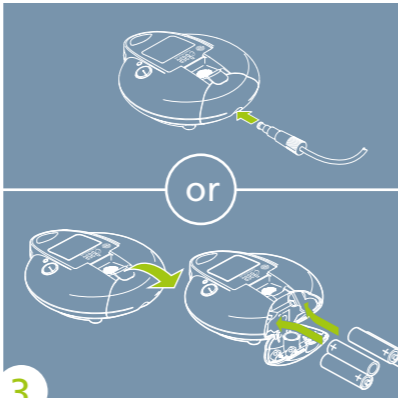
3 
 ▲ Either plug the power cord into the back of the eFlow control unit, or ensure batteries are fully charged.

6 Read and understand the PARI nebuliser instructions for use.

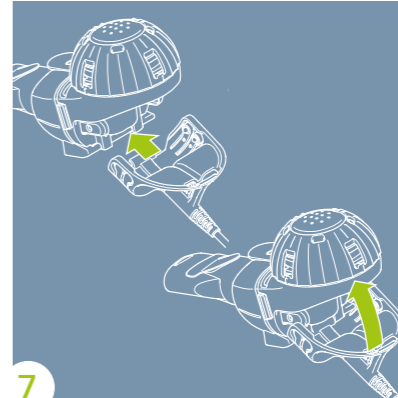
7 
 ▲ Connect the cable to the back of the nebuliser handset.

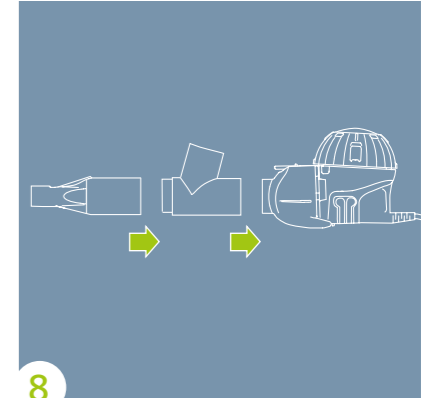
8 
 ▲ Attach the Y-piece to the handset outlet, then attach the mouthpiece without a valve to the Y-piece. ALTERNATIVELY attach the BABY mask instead of the mouthpiece.

Loading your Medication

4 
 ▲ Open the handset nebuliser package and place the contents on a clean, dry towel.

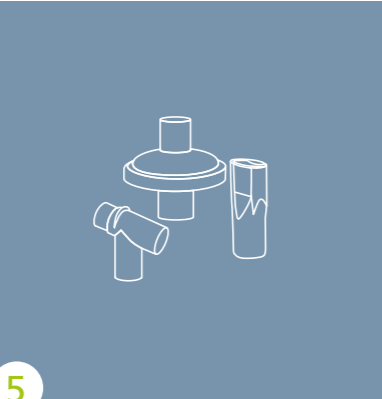
5 
 ▲ Open the contents of the PARI Filter Valve Set and place on a clean towel.

- ◀ You should have:
- 1 x Mouthpiece without valve (or BABY mask for young children/babies),
 - 1 x exhalation Filter assembly with filter pad (inside),
 - 1 x Y-piece
- N.B. Put the mouthpiece with valve away in a safe place for now. You won't need it when using the exhalation filter.

9 
 ▲ Attach the exhalation filter (with pad inside) to the top of the Y-piece.

10 
 ▲ Remove the medication cap from the top of the handset by twisting.

11 
 ▲ Add medication as prescribed into the nebuliser. Replace the medication cap.

AEROSOL TREATMENT

Position yourself comfortably in a sitting position that will allow you to take a deep breath.

1



2

▲ Place mouthpiece between teeth and top of tongue and inhale through your mouth. It is best to take slow, deep breaths whenever possible. ALTERNATIVELY if using the PARI BABY mask, place the mask comfortably over the mouth and nose of the patient.

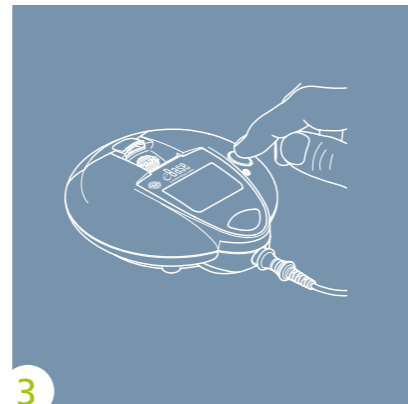

3

▲ Turn the control unit on.

Monitor for side effects. If you experience any of the following, ask your healthcare professional for advice:

- noticeable increase in heart rate or palpitations
- Dizziness or shakiness

4

Continue treatment until the nebuliser beeps and turns itself off.

If the device does not switch off automatically, switch the device off manually.

5

Store or dispose of any left-over medication as directed.

6

CLEANING

CLEANING THE NEBULISER

It is important that the nebuliser handset is cleaned immediately after each treatment to ensure proper performance, since viscous medications such as antibiotics may clog the nebuliser more easily than other medications. If you are unable to clean the nebuliser after every treatment, you must rinse the nebuliser to remove the medication residue. Then resume cleaning as soon as it is convenient.

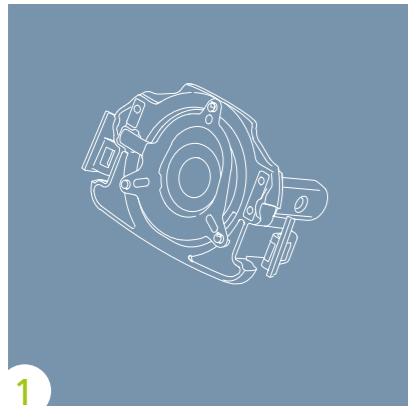

Wash your hands as instructed on page 8.

◀ Please note that the aerosol head (i.e. the metal part) requires careful handling. The central metal parts should not be touched and the aerosol head should only be handled by the plastic collar.

Completely disassemble the nebuliser parts. Discard the filter pad safely after every treatment.

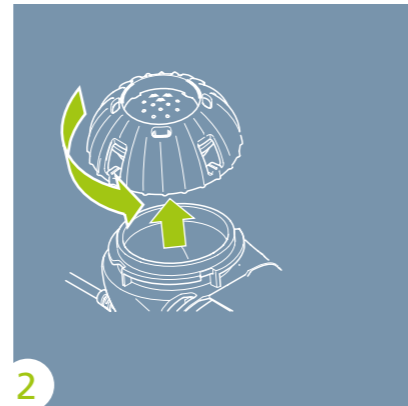

2 Remove the medication cap by twisting. Empty any remaining medication residue.



◀ WASHING: Mix a solution of warm water and washing-up liquid in a clean container. Wash all parts of the nebuliser in this solution. Rinse all parts thoroughly after washing and place between two clean towels or cloth to dry whilst keeping dust-free. Do not use kitchen towel. All parts must be completely dry before re-assembly.

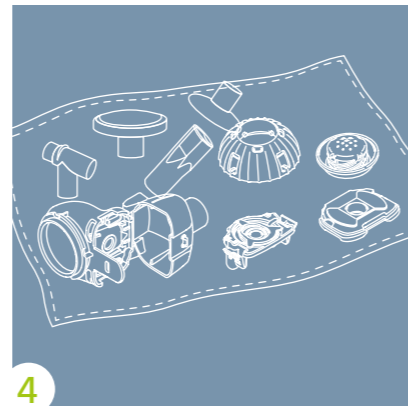

4

3

Rinse all parts of the nebuliser under a strong stream of warm water.

DISINFECTING THE NEBULISER

We recommend you disinfect the eFlow®rapid nebuliser handset every day. There are 2 options for disinfecting your nebuliser as below.

OPTION 1 – BOILING

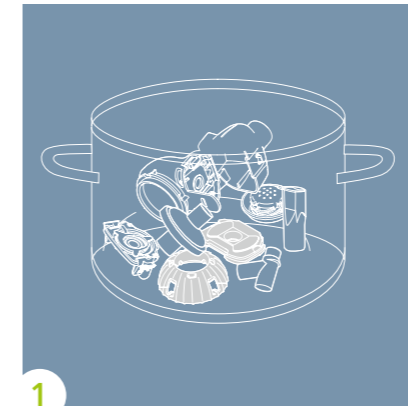

1

STEP 1: Make sure the nebuliser has been cleaned prior to disinfecting (see page 14, "Cleaning the Nebuliser")

STEP 2: Boil all parts of the nebuliser in a clean pan for at least 5 minutes. The aerosol head must only be boiled with distilled water. Place on a clean towel to dry. Cover the parts with a clean towel to keep dust free. All parts must be dry before re-assembly.

OPTION 2 – STEAM DISINFECTION

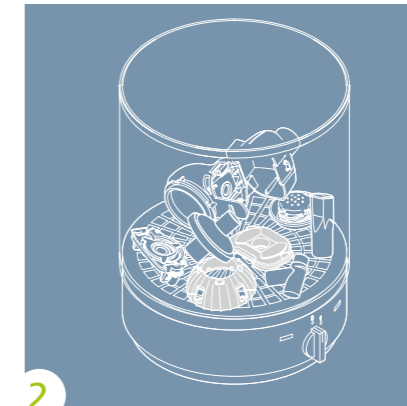

2

STEP 1: Make sure the nebuliser has been cleaned prior to disinfecting (see page 14 "Cleaning your Nebuliser")

STEP 2: Place all parts of the nebuliser into a standard disinfector for baby bottles. Follow the instructions for use. Please note you should not use a microwave disinfector for the aerosol head. Place on a clean towel to dry. Cover the parts with a clean towel to keep dust free. All parts must be dry before re-assembly.

EASYCARE CLEANING AID

Use with the eFlow®rapid

- Measure how long it takes to nebulise 2.5 ml isotonic sodium chloride solution (0.9 % saline) without inhaling.
- If the nebulisation time takes longer than 4 minutes, it is recommended to backwash the aerosol head with the easycare cleaning aid.



Please ensure that the following steps are observed to optimise easycare backwashing:

1 Clean the nebuliser parts and aerosol head as described on page 14.

2 Use the easycare – for detailed description see page 17.



3 Disinfect the nebuliser parts and aerosol head as described on page 15.

How to assemble the easycare

1



2

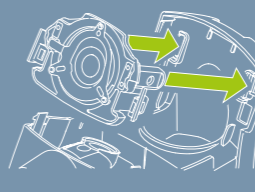

3

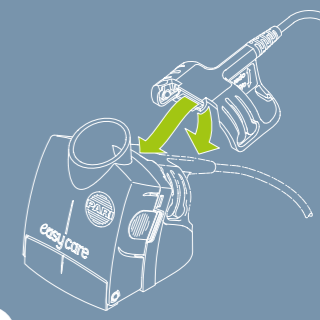

▲ Open the easycare cleaning aid. To open press lightly on the sides and pull open.

▲ Install the aerosol head and close the easycare reservoir. The eFlow® aerosol head must be felt to snap into place upon insertion. Please take care to ensure proper orientation.

▲ Connect the easycare cleaning aid to the eBase® controller. Attach the eFlow®rapid nebuliser cable to the hinge of the easycare reservoir and swivel it downwards, so that the metal contacts engage. Connect the other end of the cable to the eBase® controller.

4

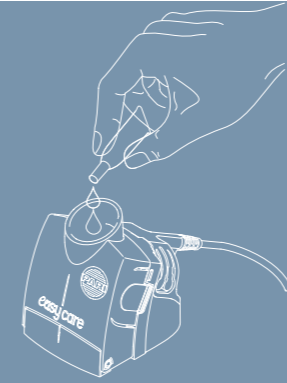

▲ Fill approx. 5 ml isotonic sodium chloride solution (0.9 % saline) into the top opening

◀ Backwash procedure: Start the backwash by pressing the start button on the eFlow® control unit. The processing time for 5 ml is at least 10 min.

After rinsing, the eFlow® control unit automatically switches off. If liquid is still present in the funnel, please restart.

Important:

The easycare backwashing procedure is performed as an additional measure to the normal cleaning of the aerosol head.

Frequency of use

If needed, use the easycare no more than 2 times per week after cleaning the aerosol head.

Note

More frequent use is **not** beneficial, and can lead to premature material wear. During its entire period of use, an aerosol head should not be backwashed more than 25 times with the easycare cleaning aid.

FREQUENTLY ASKED QUESTIONS ABOUT AEROSOL DELIVERY OF INHALED ANTIBIOTICS

DO I HAVE TO CLEAN THE NEBULISER AFTER EVERY TREATMENT?

It is essential to remove the medication residue as soon after the treatment as possible. If the residue dries, future cleaning may not remove all the residue. If you are unable to wash the nebuliser after every treatment, rinse the nebuliser thoroughly and resume cleaning as soon as possible.

HOW DO I KNOW WHEN TO REPLACE MY PARI NEBULISER?

The aerosol head alone should be replaced every 3 – 6 months. The nebuliser handset should be replaced at least every 12 months.

DO I NEED TO USE AN EXHALATION FILTER ON THE NEBULISER?

The filter is an optional accessory that will minimise aerosol escaping into the room. This may be important if you don't want family members or anyone other than the patient inhaling the antibiotic aerosol mist. Exhalation filters are used in hospitals and clinics to prevent nurses etc from inhaling the aerosol mist.

DO I NEED TO REPLACE THE ENTIRE EXHALATION FILTER SET AFTER EVERY TREATMENT?

NO – The PARI exhalation filter was designed to open so that only the filter pad is replaced. Usually the filter

pad is replaced after every treatment. Replacement filter pads are available in packs of 30, 100 or 1000.

WHERE CAN I PURCHASE THE PRODUCTS REFERENCED IN THIS BOOKLET?

If you need assistance in finding PARI products, please contact PARI Medical Ltd on 01932 341122.



PARI Medical Ltd
The Old Sorting Office
Rosemount Avenue
West Byfleet
Surrey KT14 6LB

E-Mail: infouk@pari.eu
Phone: +44 (0)1932 341122
Fax: +44 (0)1932 341134

www.pari.com