



Instructions for use

PARI COMPACT2 inhalation system

PARI COMPACT2 compressor (Type 152)

PARI LC PLUS® nebuliser (Type 022)

PARI child mask soft (Type 041)

Important: Read these instructions carefully before using the product for the first time. Follow all instructions and safety instructions!

Keep the instructions in a safe place.

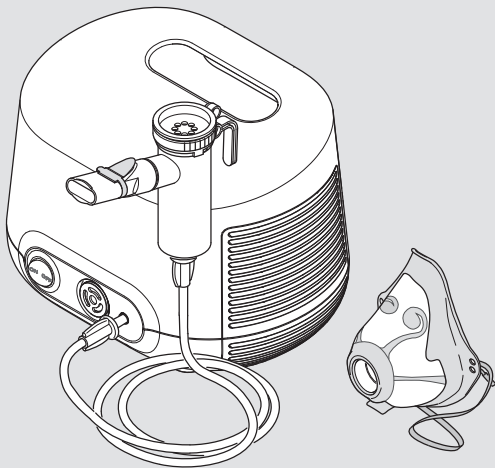

Identification, validity, version

These instructions for use are valid for PARI COMPACT2 inhalation systems in the following countries:

Countries outside the EU

Version of these instructions for use: Version F – 2020-02,

Approved version dated 2019-11-21

Information as of: 2019-11

The current version of the instructions for use can be downloaded from the internet as a PDF file:

www.pari.com (on the respective product page)

Formats available for visually impaired patients

The instructions for use available in PDF format on the internet can be enlarged for printing.

CE conformity

The product is compliant with the requirements according to:

- 93/42/EEC (Medical devices)
- 2011/65/EU (RoHS)

Trade marks

The following trade marks are registered trade marks of PARI GmbH Spezialisten für effektive Inhalation in Germany and/or other countries:

LC SPRINT®, LC PLUS®, PARI®

Copyright

©2020 PARI GmbH Spezialisten für effektive Inhalation
Moosstraße 3, 82319 Starnberg, Germany

No part of this documentation may be reproduced or processed, duplicated, translated or disseminated by electronic means without the prior, written consent of PARI GmbH.

All rights reserved. Technical and design changes and printing errors reserved. Principle shown in illustrations.

Legal manufacturer

PARI GmbH Spezialisten für effektive Inhalation
Moosstraße 3, 82319 Starnberg, Germany

Contact

For all product information and in the event of defects or questions about usage, please contact our Service Center:

Tel.: +49 (0)8151-279 220 (international)

+49 (0)8151-279 279 (German-speaking)

E-Mail: info@pari.de

TABLE OF CONTENTS

IMPORTANT INFORMATION	7
Intended purpose	7
Indication	8
Contraindications.....	8
Safety instructions	8
PRODUCT DESCRIPTION	13
Components	13
Working parts	14
Description of function	15
Material information	16
Maintenance	16
Operating life	16
APPLICATION	17
Setting up the compressor	17
Preparing for treatment	19
Performing treatment.....	22
Ending the treatment	25
REPROCESSING	26
Single patient use	26
Multiple patient use	30
Care of the connection tube	31
Replacing the air filter	31
Inspecting	32
Storage	32
TROUBLESHOOTING	33
TECHNICAL DATA	33
Compressor	33
Nebuliser	36

MISCELLANEOUS	38
Disposal	38
Links	39
Labelling	39
APPENDIX: Reprocessing in professional environments for use with several patients	41
Compressor	41
Nebuliser and accessories	41
Connection tubing	44

1 IMPORTANT INFORMATION

1.1 Intended purpose

The PARI inhalation system consists of a PARI compressor, a PARI nebuliser and PARI accessories. The system is used for treatment of the lower airways.

The inhalation system must only be used by individuals who understand the contents of the instructions for use and are able to operate the inhalation system safely. Individuals in the following groups must be supervised by a person who is responsible for their safety:

- Babies, infants and children
- Individuals with limited capabilities (e.g., physical, mental, sensory)

If the patient is not able to operate the inhalation system safely himself, the therapy must be carried out by the responsible person.

Compressor

The purpose of the PARI compressor is to generate compressed air for operating a PARI nebuliser.

The PARI compressor is intended for use with multiple patients. It must only be used for PARI nebulisers. The compressor can be operated by the patient himself and must only be used indoors.

Nebuliser

The nebuliser generates aerosols¹ for inhalation.

The nebuliser must only be used in a home environment and only by a single patient for reasons of hygiene. It is suitable for use in treating patients in all age groups.

Only solutions and suspensions that are approved for use in nebuliser therapy may be used.

1) Aerosol: Small particles of solid, liquid or mixed composition (fine "mist") suspended in gases or air.

An application takes between 5 and 10 minutes (depending on the quantity of fluid), but in no case more than 20 minutes.

The frequency and duration of use will be determined by the physician or therapist according to the individual needs of the patient.

Mask

The mask is an accessory for nebuliser treatment with a PARI nebuliser.

The PARI child mask soft is suitable for the treatment of children aged 4 years and older².

The mask must only be used with PARI nebulisers.

For reasons of hygiene, this PARI product must only be used in a home environment by a single patient.

1.2 Indication

For treatment of diseases of the lower airways.

1.3 Contraindications

This product is only designed for patients who are able to breathe by themselves and are conscious.

1.4 Safety instructions

The present instructions for use contain important information, safety instructions and precautionary measures.

The user must follow these in order to guarantee safe operation of this PARI product.

This PARI product must only be used as described in these instructions for use.

The instructions for use of the inhalation solution used must also be followed.

2) The age indicated is intended as a guidance value. Whether the mask is actually suitable depends on the size and shape of the individual face.

General

Nebuliser aerosol characteristics differ from the information provided by the manufacturer if non-approved solutions or suspensions are used for nebulisation.

This product is not suitable for use in an anaesthetic breathing system or a ventilator breathing system.

Tracheotomised patients cannot inhale with a mouthpiece. For inhalation therapy, they require specific equipment. In this case, please contact your doctor for further information.

If your health condition is not improved, or even worsens as a result of the treatment, seek professional medical advice.³

Danger of electrocution

The compressor is an electrical device that is powered by supply voltage. It has been designed so that no live parts are accessible. However, if ambient conditions are unfavourable or if the compressor or power cord is damaged, this protection may no longer be provided. It may then be possible to come into contact with live parts. This in turn may lead to an electric shock. To avoid this danger, follow the instructions below:

- Make sure that the compressor housing, the power cord and the power plug are undamaged every time before use. The compressor must not be operated
 - if the housing, the power cord or the power plug is damaged,
 - if a fault is suspected following a fall or similar.
- Never leave the compressor unattended while it is in use.
- Plug the compressor into an easily accessible socket. It should be possible to unplug the power plug at all times.
- Switch the compressor off and disconnect the power plug from the mains socket immediately:

3) Professional medical staff: Doctors, pharmacists and physiotherapists.

- if it is suspected that the compressor or the power cord might have been damaged (e.g., after the compressor has fallen or if there is a smell of burning plastic)
- if a malfunction occurs during operation
- before cleaning and maintaining the device
- immediately after use
- Keep the power cord away from domestic animals (e.g., rodents). They may damage the insulation on the power cord.

Hazard due to small parts which can be swallowed

The product contains small parts. Small parts can block the airways and lead to a choking hazard. Keep all components of the product out of the reach of babies and infants at all times.

Danger of a device defect

Comply with the following instructions to avoid a device defect:

- Make sure that the local supply voltage matches the voltage data marked on the compressor identification label.
- To avoid overheating of the compressor,
 - Never operate the compressor while it is in a bag,
 - Never cover the compressor while it is operating,
 - Make sure that the ventilation slits on the compressor are unobstructed at all times while it is operating.
- Always pull the power cord by the power plug, not the cable, to disconnect it from the socket.
- Make sure that the power cord is never kinked, pinched or jammed. Do not pull the power cord over sharp edges.
- Keep the compressor and the power cord away from hot surfaces (e.g., stove top, electric fire, open fire). Direct heat may damage the compressor housing or the insulation on the power cord.

Impairment of treatment due to electromagnetic interference

Use only original spare parts and original accessories from PARI. The use of third party products can result in increased emissions of electromagnetic interference or reduced resistance of the PARI compressor.

Hygiene

Observe the following hygiene instructions:

- Do not use product components unless they have been thoroughly cleaned and dried. Contamination and residual moisture encourage the growth of bacteria, which increases the risk of infection.
- Before every use and cleaning, wash your hands thoroughly.
- It is essential to clean and dry all product components before the first application as well.
- Always use drinking water for cleaning and disinfecting.
- Dry all product components completely after each cleaning and disinfection.
- Do not keep the product components in a damp environment or together with damp objects.

Treatment of babies, infants, and anyone who requires assistance

For individuals who are not able to perform the therapy session without assistance or cannot appreciate the hazards, the risk of injury is greater (e.g., strangulation with the power cord or the connection tubing). Such individuals include for example babies, children and people with limited capabilities. For these individuals, a person responsible for safety must supervise or carry out the application.

Identifying and classifying warning instructions

Safety-critical warnings are categorised according to the following hazard levels in these instructions for use:

DANGER

DANGER indicates a hazardous situation which will lead to severe injuries or death if it is not avoided.

WARNING

WARNING indicates a hazardous situation which can lead to severe injuries or death if it is not avoided.

CAUTION

CAUTION indicates a hazardous situation which can lead to mild or moderate injuries if it is not avoided.

NOTE

NOTE indicates a situation which can lead to material damage if it is not avoided.

2 PRODUCT DESCRIPTION

2.1 Components

The following components are included in the package (these may differ from the picture on the packaging):

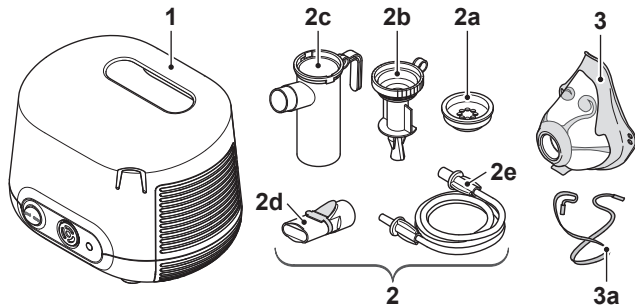

(1)	Compressor
(2)	PARI LC PLUS nebuliser
(2a)	Inspiratory valve
(2b)	Nozzle insert (transparent)
(2c)	Nebuliser lower part
(2d)	Mouthpiece
(2e)	Connection tubing
(3)	PARI child mask soft
(3a)	Elastic band

2.2 Working parts

The compressor includes the following working parts:

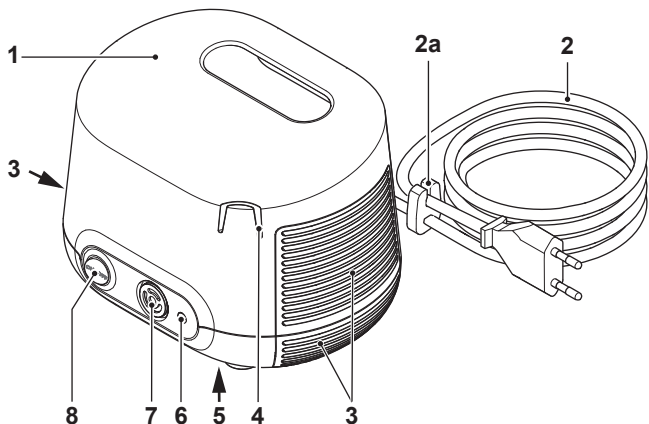

(1)	Carrying handle
(2)	Power cord ⁴ (connected inseparably to the compressor)
(2a)	Cable holder
(3)	Ventilation slits
(4)	Holder for nebuliser
(5)	Identification label (bottom of device)
(6)	Air connection
(7)	Air filter
(8)	On/off switch

4) The power plug type is country-specific. The figure shows the europlug (type "C").

2.3 Description of function

Compressor with nebuliser

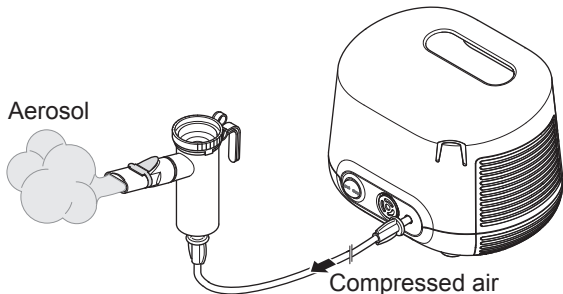

The compressor supplies the nebuliser with compressed air. When compressed air is supplied, the nebuliser generates an aerosol from the liquid, for example the medication with which it is filled. This aerosol is breathed into the lungs through the mouth-piece or optionally a mask.

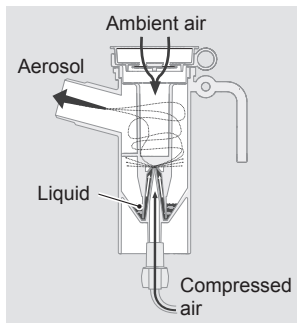

Mask

The mask makes it possible to inhale aerosol through the mouth and the nose.

The patient can breathe out through the exhalation valve at the bottom end of the mask without having to take the mask off.

The mask can be held firmly in position on the face with the aid of the elastic band which is attached to the side openings of the mask.

2.4 Material information

The individual product components are made from the following materials:

Product component	Material
Inspiratory valve	Polypropylene, silicone
Nozzle insert	Polypropylene
Nebuliser lower part	Polypropylene
Mouthpiece (with exhalation valve)	Polypropylene, thermoplastic elastomer
Connection tubing	Polyvinyl chloride
Tubing endpiece	Thermoplastic elastomer
PARI child mask soft	Polypropylene, thermoplastic elastomer
Elastic band	Synthetic rubber

2.5 Maintenance

The compressor is maintenance free.

2.6 Operating life

The individual product components have the following expected lifetimes:

Product component	Operating life
Compressor	Approx. 500 operating hours (this corresponds to max. 3 years) If the compressor is still in use after this time, have the compressor tested. To do this, contact the manufacturer or distributor.
Nebuliser (all components except the connection tubing)	300 disinfections, max. 1 year
Connection tubing	max. 1 year
PARI child mask soft	300 disinfections, max. 1 year

3 APPLICATION

People who assist others in carrying out the therapy must ensure that all of the steps described below are carried out correctly.

If the nebuliser is to be operated via a PARI CENTRAL on a central medical gas supply, the instructions for use of the PARI CENTRAL must be followed.

3.1 Setting up the compressor

The room in which the compressor is operated must satisfy certain requirements [see: During operation, page 35]. Furthermore, please note the following warnings before setting the compressor up:



WARNING

Risk of fire due to a short circuit

A short circuit in the compressor can cause a fire. In order to reduce the risk of fire in such an event, follow the instructions below:

- Do not operate the compressor close to readily flammable objects such as curtains, tablecloths, or paper.
- Do not operate the compressor in areas where there is a risk of explosion or in the presence of oxidising gases (e.g., oxygen, nitrous oxide, flammable anaesthetics).

 **CAUTION**

Quality of treatment impaired by electromagnetic interference

Electrical devices can cause electromagnetic interference. Interference can impair the function of the devices and thus also the effectiveness of the treatment.

- Do not place the PARI device immediately beside or on top of other devices.
- Keep at a minimum distance of 30 cm from portable wireless communication devices (including accessories therefor, such as antenna cables or external antennas).
- If the PARI device has to be placed immediately beside or on top of other devices for operation, all devices must be monitored to ensure that they are working properly.

 **CAUTION**

Danger of injury from falling compressor

A compressor placed in a poor position poses a risk of injury.

- Do not place the compressor above head height.
- Make sure that it cannot be pulled down by the power cord or the connection tube.
- Do not place the compressor on a soft surface such as a sofa, a bed or a tablecloth.

NOTE

Danger of device fault caused by dust

If the compressor is operated in a very dusty atmosphere, more dust may collect inside the housing. This may cause a fault in the device.

- Do not operate the compressor on the floor, under the bed or in workshops.
- Only operate the compressor in a low-dust environment.

Set the compressor up as follows:

- Place the compressor on a firm, flat, dust-free, dry surface.
- Plug the power plug into a suitable socket.

⚠ CAUTION! Route the power cord in such a way that it is not a tripping hazard and no one can become entangled in it. Poorly routed cable connections pose a risk of injury.

3.2 Preparing for treatment

Assembling the nebuliser

⚠ CAUTION

Risk of impaired treatment

Damaged components and/or an incorrectly assembled nebuliser may impair functioning of the nebuliser and thus treatment as well.

- Check all nebuliser components and the accessories before each use.
 - Replace any broken, misshapen or seriously discoloured parts.
 - Follow the assembly instructions in these instructions for use.
-
- Insert the nozzle insert in the nebuliser lower section.
 - Gently twist the nozzle insert clockwise to lock it in place.

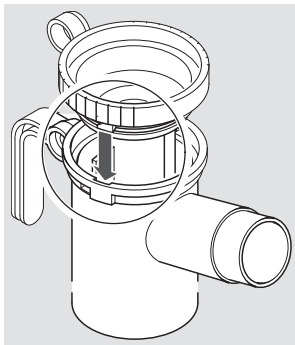

- Attach the connection tubing to the nebuliser.

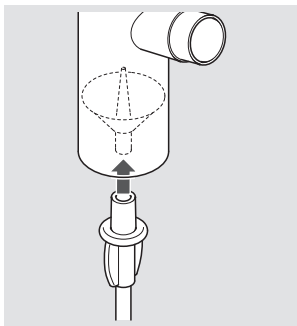

Using the mouthpiece

- Fit the mouthpiece onto the nebuliser.

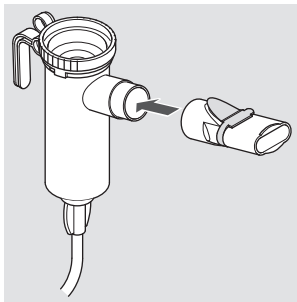

Using the mask

- If desired, attach the elastic band to the mask (as shown in the figure).

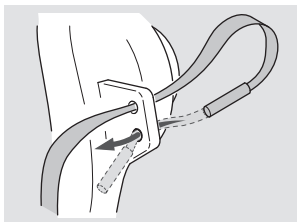

- If applicable, detach the mouthpiece from the nebuliser.
- Attach the mask to the nebuliser.

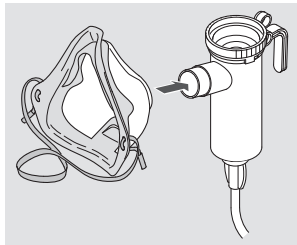

Filling the nebuliser

- Insert the nebuliser in the holder on the compressor intended for this purpose.
- If applicable, detach the inspiratory valve from the nebuliser.
- Pour the required quantity of inhalation solution into the top of the nebuliser.

Note the minimum and maximum fill volumes [see: General nebuliser data, page 36]. If the nebuliser contains too little or too much liquid, the nebulisation and consequently the therapy will be less effective.

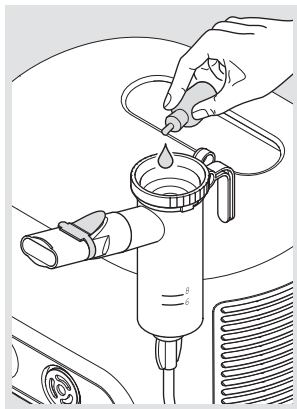

- Fit the inspiratory valve onto the nebuliser.

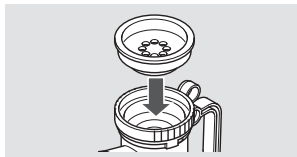

If several inhalation solutions are to be used one after the other:

- Rinse the nebuliser out with drinking water between the individual applications.
- Shake excess water out of the nebuliser.
- Fill the nebuliser with the next inhalation solution as described.

3.3 Performing treatment

All of the safety instructions in these instructions for use must have been read and understood before any treatment is carried out.

i Always hold the nebuliser upright during treatment.

Proceed as follows in order to carry out the treatment:

- Insert the connection tubing of the nebuliser with a slight twist into the air connection on the compressor.

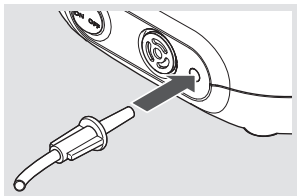

⚠ DANGER! Life-threatening situation caused by mixing up tubes!

If tubing systems for other devices are present close by (e.g., for infusions), check carefully to ensure that the other end of the connection tubing connected to the compressor is connected to the nebuliser. Otherwise, there is a danger that different possible connections may be confused with each other.

- Take the nebuliser out of its holder and hold it upright.
- Verify that all parts are firmly connected to each other.

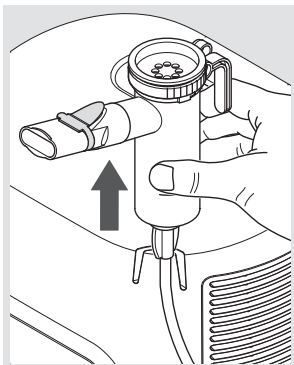

- Switch the compressor on.
⚠ DANGER! Danger of death by electrocution in the case of device fault! Switch the compressor off and disconnect the power plug from the mains socket immediately if a fault is suspected (e.g., following a fall or if there is a smell of burning plastic). If there is a fault in the device, it may be possible to come into contact with live parts. This in turn may lead to an electric shock.

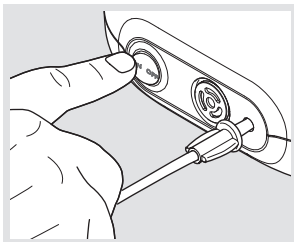

- Check that an aerosol is being generated before you begin the treatment.

Inhaling with the mouthpiece

- Sit in an upright position and relax.
- Hold the mouthpiece between your teeth and enclose it with your lips.
- Breathe in as slowly and deeply as possible through the mouthpiece, and out again calmly.

- Carry out the inhalation treatment until the noise in the nebuliser changes.

i *Some residual fluid will remain in the nebuliser after the end of the treatment.*

Inhaling with the mask

CAUTION

Impaired treatment due to escaping aerosol

If the mask does not form a seal on the face, aerosol may escape. This may result in medication underdosage.

- Make sure that the mask completely covers both corners of the mouth and the nose.
- Take note of possible side effects caused by escaping aerosol. These are described in the information for use of the respective medication.
- Check whether the exhalation valve is pressed outwards, to ensure that the user can breathe out freely during the inhalation session.
- Hold your child steady while he/she sits upright and calm.
- Gently press the mask against the face so that it fits snugly over the mouth and nose. Make sure that the nebuliser is upright.
- If desired, use the elastic band to hold the mask in place against the face. The elastic band should pass round the back of the head.

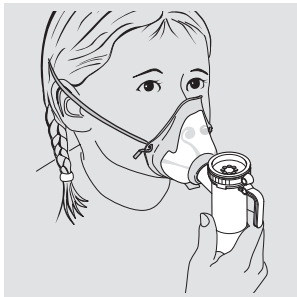
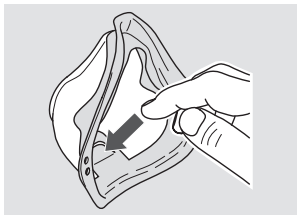

Teach the child to perform the following inhalation manoeuvre:

- Breathe in as slowly and deeply as possible through the mask and out again calmly.
 - Continue inhaling until the noise in the nebuliser changes.
- i** *Some residual fluid will remain in the nebuliser after the end of the treatment.*

3.4 Ending the treatment

To end the treatment, proceed as follows:

- Switch the compressor off.
 - Place the nebuliser back in the holder on the compressor.
 - Disconnect the power plug from the mains socket.
- i** *Complete disconnection from the mains is only certain when the power plug has been unplugged from the socket.*

4 REPROCESSING

DANGER

Danger of electrocution

Liquids can conduct electricity, thereby posing a risk of electric shock.

- Always switch the compressor off and disconnect the power plug from the mains socket before starting to clean it.

If the inhalation system is used **by only one patient**, follow the instructions for cleaning and disinfecting in the section "Single patient use" [see: Single patient use, page 26].

If the inhalation system is used **by several patients**, follow the instructions for cleaning and disinfecting in the section "Multiple patient use" [see: Multiple patient use, page 30].

If the inhalation system is used **in professional environments**, follow the information on reprocessing included in the appendix at the end of these instructions for use.

4.1 Single patient use

Cleaning and disinfection cycles

Compressor housing	Clean when visibly dirty
Nebuliser (without connection tubing) and mask	<ul style="list-style-type: none"> – Clean immediately after every use – Disinfect at least once a day
Air filter	Replace after 200 operating hours (approx. 1 year)

Nebuliser and mask

The mask can be cleaned, disinfected and dried together with the nebuliser.

Preparation

MASK

- Detach the mask from the nebuliser.
- Detach the elastic band from the mask.

NEBULISER

- Detach the tube from the nebuliser.
- Detach the mouthpiece from the nebuliser.
- Make sure that all residual volume is removed from the nebuliser.
- Dismantle the nebuliser into its individual parts.
- Carefully pull the blue exhalation valve out of the slot in the mouthpiece. The exhalation valve must still be attached to the mouthpiece.

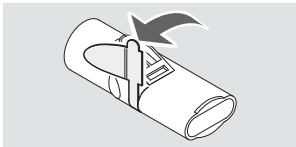

Cleaning

i *The connection tube cannot be cleaned or disinfected. Regarding care of the connection tube, follow the instructions in the corresponding section [see: Care of the connection tube, page 31].*

ELASTIC BAND

- Clean the elastic band as necessary with warm drinking water and a little dishwashing liquid.

NEBULISER AND MASK

- Briefly rinse all parts used in running drinking water beforehand.
- Place all disassembled components in warm drinking water with a little dishwashing liquid for about 5 min.

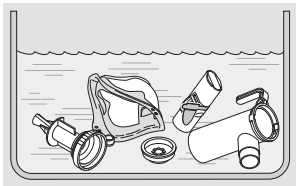

- Rinse off all parts thoroughly in drinking water.
- Shake the water out of all of the parts.

Disinfecting

After cleaning, disinfect all of the **disassembled parts** (only parts that have been cleaned can be disinfected effectively).

The recommended disinfection procedures are described below. Descriptions of other validated disinfection procedures are available from the manufacturer or dealer upon request.

i *The connection tube cannot be cleaned or disinfected. Regarding care of the connection tube, follow the instructions in the corresponding section [see: Care of the connection tube, page 31].*

i *The elastic band cannot be disinfected.*



CAUTION

Risk of infection due to moisture

Moisture encourages the growth of bacteria.

- Remove all parts from the pot or disinfecter as soon as the disinfection process is finished.
- Dry all parts.

IN BOILING WATER

- Place all the **individual parts** in boiling water for at least 5 minutes. Use a clean pot and drinking water.

NOTE! Risk of damage to plastic parts! Plastic will melt if it comes into contact with the hot base of the pot. Make sure there is enough water in the pot to prevent the individual parts from touching the pot base.

- Shake the water out of all of the parts.

USING A STANDARD THERMAL DISINFECTOR FOR BABY BOTTLES (NOT A MICROWAVE OVEN)

CAUTION

Risk of infection due to inadequate disinfection

Inadequate disinfection encourages the growth of bacteria and thus increases the risk of infection.

- Make sure that the disinfectant is clean and operating properly before every disinfection process.
- Allow the disinfection to continue until the disinfectant switches off automatically or the minimum disinfection time stated in the instructions for use of the disinfectant has elapsed. Do not switch the device off prematurely.

Use a thermal disinfectant with a runtime of at least 6 minutes. Regarding the performance of the disinfection, the duration of the disinfection procedure and the quantity of water required, follow the instructions for use of the disinfectant you are using.

Drying

After each cleaning and disinfection, place all product components on a dry, clean and absorbent surface and let them dry completely.

Cleaning the compressor housing

NOTE

Danger of device fault due to liquid penetration

If liquids get into the interior of the compressor, this may cause a fault in the device.

- Never immerse the compressor in water.
- Never clean the compressor in running water.
- Never spray any liquids onto the compressor or the power cord.
- If liquid does get into the compressor, it must not be used under any circumstances. Before starting the compressor again, contact the manufacturer or dealer.

Clean the compressor housing as follows:

- Wipe the outer surface of the housing with a clean, damp cloth.

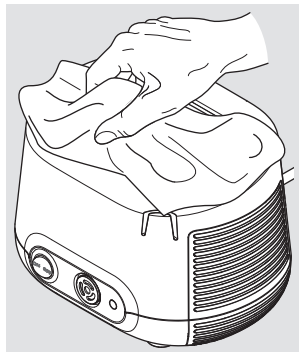

4.2 Multiple patient use

Cleaning and disinfection cycles

Nebuliser (with connection tubing) and mask	Replace before each patient change
Compressor housing	Disinfect before each patient change
Air filter	Replace after 200 operating hours (approx. 1 year)

Nebuliser and mask

The nebuliser and mask are not suitable for use by multiple patients. Use a separate nebuliser (including connection tubing) and a separate mask for each patient.

Disinfecting the compressor housing

For disinfection, use a standard, alcohol-based disinfectant (e.g., isopropanol). Regarding the use and quantity of the disinfectant, it is imperative to follow the information for use of the agent used.

To disinfect the compressor, proceed as follows:

- If the compressor is visibly dirty, clean the compressor before disinfecting it [see: Cleaning the compressor housing, page 30].
- Moisten a cloth with the disinfectant.

NOTE! Danger of device fault due to liquid penetration.

Never spray any liquids onto the compressor or the power cord. If liquid does get into the compressor, it must not be used under any circumstances. Before starting the compressor again, contact the manufacturer or distributor.

- Wipe the outer surfaces of the housing off thoroughly with the cloth.

4.3 Care of the connection tube

Dry the connection tube after every inhalation session:

- Connect the connection tube to the compressor.
- Switch your compressor on.
- Leave the compressor to work until the air flowing through the tube has removed all traces of any condensation in the tube.

4.4 Replacing the air filter

The air filter must be checked at regular intervals (after every 10th application). If it is discoloured brown or grey, or if it is damp or clogged, it must be replaced.

In all cases, it must be replaced after 200 operating hours (approx. 1 year).

The air filter cannot be cleaned and then reused!

Take the air filter out:

- Pull the filter holder out of the compressor. Use a small screwdriver, for example, to prise the filter holder carefully out of the compressor.

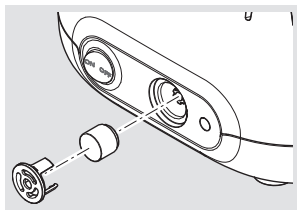

Replace the air filter:

- Pull the old air filter out of the filter holder and fit the new filter in its place.

NOTE! Only use air filters provided by the manufacturer or dealer for operating your compressor. If air filters that are not designed for the compressor are used, the compressor may be damaged.

- Insert the filter holder back in the compressor.

4.5 Inspecting

Inspect all product components after each cleaning and disinfection. Replace any broken, misshapen or seriously discoloured parts.

4.6 Storage

Store this product as described below:

- Wind the power cord up loosely.

NOTE! Do not wind the power cord around the compressor. If the power cord is wound or bent very tightly, the wires inside the cord may break. The power cord will then be unusable.

- Wrap all individual components in a clean, lint-free cloth (e.g., a tea towel).
- Store this product in a dry, dust-free place.

i *Unplug the power plug from the socket when putting the compressor away. Electrical devices that remain plugged into the power supply present a potential hazard source.*

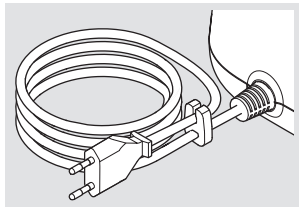

5 TROUBLESHOOTING

The compressor must not be repaired except by the Technical Service of PARI GmbH or a service center expressly authorised to do so by PARI GmbH. If the compressor is opened or manipulated by anyone else, all claims under the warranty shall be void. In these cases, PARI GmbH will accept no liability.

Fault	Possible cause	Remedy
The compressor does not start up.	The power plug is not plugged into the mains socket properly.	Check whether the power plug is plugged into the socket correctly.
	The supply voltage is not suitable for running the compressor.	Check whether the local supply voltage matches the voltage data marked on the compressor identification label.
No aerosol is coming out of the nebuliser.	The nebuliser nozzle insert is blocked.	Clean the nebuliser.
	The connection tubing is not connected properly.	Check that the tubing connectors are connected firmly to the compressor and the nebuliser.
	The connection tubing is leaking.	Replace the connection tubing.

6 TECHNICAL DATA

6.1 Compressor

General compressor data

Supply voltage [V] Mains frequency [Hz] Power consumption [A]	see label on confirmation of purchase
---	---------------------------------------

Housing dimensions (W × H × D)	18.5 cm × 13.0 cm × 15.0 cm
Weight	1.55 kg
Pressure ⁵	1.2 bar
Compressor flow ⁵	4.1 l/min
Sound pressure level	56 dB(A)

Classification according to IEC 60601-1 / EN 60601-1

Type of electric shock protection	Protection class II
Degree of protection from electric shock of the applied part (nebuliser)	Type BF
Degree of protection according to IEC 60529 / EN 60529 against penetration by water and solid substances	IP 21
Degree of protection when used in the presence of flammable mixtures of anaesthetics with air, with oxygen, or with nitrous oxide	No protection
Operating mode	Continuous operation

Electromagnetic compatibility

Electrical medical equipment is subject to special precautionary measures with regard to electromagnetic compatibility (EMC). Such equipment must only be installed and operated in accordance with EMC instructions.

Portable and mobile high-frequency communication devices can disrupt electrical medical equipment. Using accessories, converters and power cords other than those specified (with the exception of converters and power cords that the

5) Towards nebuliser nozzle (Ø 0.48 mm).

manufacturer of the medical electrical device sells as spare parts for internal components) can result in higher emission levels or lower the resistance to interference of the device. The device must not be placed directly beside or on top of other devices for operation. If the medical electrical device must be placed beside or on top of other devices to operate it, it must be monitored constantly to ensure that it is operating properly in the arrangement used.

Technical data on electromagnetic compatibility (EMC information) is available in table format upon request from the manufacturer or dealer or on the internet at the following linked page:

<https://www.pari.com/fileadmin/Electromagnetic-compatibility-5.pdf>

Ambient conditions

During operation

Ambient temperature	+10 °C to +40 °C
Relative humidity	30% to 75% (non-condensing)
Atmospheric pressure	700 hPa to 1,060 hPa

The compressor is intended for operation in all healthcare situations. It is not permitted to operate it in trains, motor vehicles or aeroplanes.

Use of the compressor in professional healthcare facilities is limited to the inpatient wards and the intensive care unit. Use of the compressor in areas with elevated magnetic or electrical radiation (e.g., close to an MRI scanner) is not permitted.

During transportation and storage

Minimum ambient temperature (without monitoring of relative humidity)	-25 °C
Maximum ambient temperature (with relative humidity of up to 93%, non-condensing)	+70 °C
Humidity	max. 93%

Atmospheric pressure	500 hPa – 1,060 hPa
----------------------	---------------------

6.2 Nebuliser

General nebuliser data

Size ⁶	10 cm × 9.5 cm × 4.5 cm
Weight ⁶	27.5 g to 29.5 g
Operating gases	Air
Minimum compressor flow	3.0 l/min.
Minimum operating pressure	0.5 bar / 50 kPa
Maximum compressor flow	6.0 l/min.
Maximum operating pressure	2.0 bar / 200 kPa
Minimum fill volume	2 ml
Maximum fill volume	8 ml; PARI LC STAR: 6 ml

6) Without mouthpiece and mask; unfilled.

Aerosol data according to ISO 27427

The aerosol characteristics presented in these instructions for use were determined in accordance with ISO 27427 using Salbutamol. If other solutions or suspensions are used for nebulisation, the aerosol characteristics may differ from the values shown (particularly if they have greater viscosity).

The following data is based on tests according to a standard which takes adult breathing patterns as a basis. Therefore, these figures will probably differ from corresponding figures that were calculated for populations of children and infants.

Nozzle insert (transparent)	Minimum compressor flow (3 l/min – 0.6 bar)	Nominal compressor flow (4 l/min – 1.2 bar) ⁷	Maximum compressor flow (6 l/min – 1.9 bar)
MMAD [μm] ⁸	5.4	4.5	3.4
GSD ⁹	2.13	2.23	2.31
Respirable fraction [% < 5 μm]	44.0	53.2	66.2
Aerosol fraction [% < 2 μm]	11.6	17.9	28.1
Aerosol fraction [% > 2 μm < 5 μm]	32.4	35.3	38.1
Aerosol fraction [% > 5 μm]	56.0	46.8	33.8
Aerosol output [ml]	0.30	0.40	0.38
Aerosol output rate [ml/min]	0.09	0.12	0.14
Residual volume [ml] (gravimetric)	1.28	1.15	1.14

7) Operation with PARI COMPACT2 compressor (Type 152).

8) MMAD = Mass Median Aerodynamic Diameter

9) GSD = Geometric Standard Deviation

Nozzle insert (transparent)	Minimum compressor flow (3 l/min – 0.6 bar)	Nominal compressor flow (4 l/min – 1.2 bar) ⁷	Maximum compressor flow (6 l/min – 1.9 bar)
Percentage of fill volume emitted per minute [%/min]	4.4	5.9	6.9

7 MISCELLANEOUS

7.1 Disposal

Compressor

This product falls within the scope of the European Council Directive on Waste Electrical and Electronic Equipment (WEEE)¹⁰. Accordingly, this product must not be disposed of with domestic waste. The disposal regulations prevailing in the respective member countries must be observed (e.g., disposal by local authorities or dealers). Materials recycling helps to reduce the consumption of raw materials and protect the environment.

All other product components

All other product components included in your PARI inhalation system can be disposed of with domestic waste unless other regulations apply in the country where you are located.

¹⁰) Directive 2012/19/EU of the EUROPEAN PARLIAMENT AND THE EUROPEAN COUNCIL of July 4, 2012 on waste electrical and electronic equipment.

7.2 Links











Warranty conditions:
[www.pari.com/
 warranty-conditions](http://www.pari.com/warranty-conditions)







Technical data regarding electro-
 magnetic compatibility:
[https://www.pari.com/fileadmin/
 Electromagnetic-compatibility-5.pdf](https://www.pari.com/fileadmin/Electromagnetic-compatibility-5.pdf)

7.3 Labelling

The following symbols can be found on the product components and/or the packaging:

	This product satisfies the requirements of 93/42/EEC (Medical devices) and 2011/65/EU (RoHS).
	Follow the instructions for use
	Consult instructions for use
	Item number
	Production batch number, lot
	Serial number
	On / Off
	Alternating current
	Protection class of the applied part: Type BF

	Protection class II device
IP21	The device is protected against drip water (degree of protection according to IEC 60529 / EN 60529).
	Temperature limit
	Humidity, limit
	Air pressure, limit
	Legal manufacturer

APPENDIX: Reprocessing in professional environments for use with several patients

Compressor

In general, it is recommended to disinfect the surface of the compressor – if necessary – with a disinfectant which is suitable for use in wipe disinfection of plastics according to the DGHM or VAH list [see: Disinfecting the compressor housing, page 30].

Ensure that no liquid gets into the device, as this might damage the device.

Nebuliser and accessories

The following overview of the processing steps in professional environments applies to the following products:

- Nebuliser
- PARI child mask soft (without elastic band)

1. Preparation

Disassemble the product [see: Preparation, page 26].

Check:

- Expiry date of the cleaning agent/disinfectant
- Processing limits reached?

2. Cleaning and disinfection

Manual cleaning:	pH-neutral, enzymatic cleaner, e.g., Korsolex® Endo Cleaner (Bode) or Bodedex® forte (Bode) Use: In accordance with manufacturer information, if dirt is visible use a brush if necessary.
Manual disinfection:	<p>With aldehyde-containing instrument disinfectant, e.g., Korsolex® Basic (Bode) Use: In accordance with manufacturer information Active agent basis: – Aldehyde donor ¹ – Aldehyde ¹</p> <p>With aldehyde-free instrument disinfectant Use: In accordance with manufacturer information Active agent basis: Quaternary ammonium compound <i>Info: Bomix® plus cleans and disinfects in a single work step</i></p>
Mechanical cleaning with disinfection:	Neutral cleaning agent, e.g., neodisher® Medizym (Dr. Weigert) or alkaline cleaning agent, e.g., neodisher® MediClean forte 0.5% (Dr. Weigert) in conjunction with neutraliser, e.g., neodisher® Z (Dr. Weigert) Equipment: Cleaning device and disinfectant in conformance with DIN EN ISO 15883, e.g., RDG G7836 CD (Miele) Vario TD programme or comparable valid programmes

1) Additional activity spectra: tuberculocidal, mycobactericidal, fungicidal
According to the information supplied by the disinfectant manufacturers, the agents listed are effective against the gram-positive bacteria *Staphylococcus aureus* and *Enterococcus hirae* and against the gram-negative bacteria *Escherichia coli*, *Pseudomonas aeruginosa* and *Proteus mirabilis* as well as the yeast-like fungus *Candida albicans*.

3. Steam sterilisation

Equipment:

- Steam steriliser (preferably with fractionated pre-vacuum) in accordance with DIN EN 285 or DIN EN 13060 (Type B)
- Sterile barrier system in accordance with DIN EN 11607
- Mask stabiliser

Temperature / Duration:

134 °C for at least 3 min.

Info: Always use the mask stabiliser when sterilising because otherwise it may lose its shape under the effects of high temperatures. For this purpose, follow the instructions for use of the mask stabiliser as well.

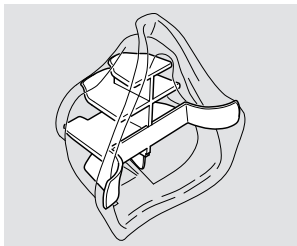

4. Visual inspection & storage

Check:

Inspect all individual parts. Replace any broken, misshapen or seriously discoloured parts.

Storage location:

- dry
 - dust-free
 - protected from sources of contamination
- optional: Use sterile packaging

Processing limits

max. 300 disinfection cycles, max. 1 year

Connection tubing

1. Preparation

Check the product:

- Expiry date of the cleaning agent/disinfectant
- Processing limits reached?

2. Cleaning and disinfection

Manual cleaning:	not applicable
Manual disinfection:	not applicable
Mechanical cleaning with disinfection:	Alkaline cleaning agent, e.g., neodisher® MediClean forte (Dr. Weigert) in conjunction with neutralising agent, e.g., neodisher® Z (Dr. Weigert) Equipment: <ul style="list-style-type: none">– Cleaning device and disinfector in conformance with DIN EN ISO 15883, e.g., RDG G7836 CD (Miele)– Special baskets for Miele instrument dishwasher– Compressed air source for blowing dry Vario TD programme or comparable valid programmes

3. Steam sterilisation

not usable

4. Visual inspection & storage

Inspect all individual parts. Replace any broken, misshapen or seriously discoloured parts.

Storage location:

- dry
- dust-free
- protected from sources of contamination
- optional: Use sterile packaging

Processing limits

max. 50 processing cycles

PARI COMPACT2 inhalation system

CERTIFICATE OF GUARANTEE

We guarantee the compressor for 2 years. The warranty period commences on the date of purchase.



Barcode

Proof of purchase:

The product with the serial number stated above was sold in its original packaging by us.

Date of purchase

Stamp and signature of the dealer

-----
©2020 PARI GmbH Spezialisten für effektive Inhalation, 152D2102_en-F 2020-02-07



PARI GmbH

Spezialisten für effektive Inhalation

Moosstraße 3

82319 Starnberg • GERMANY

info@pari.de • www.pari.com



Instrucciones de uso

Sistema de inhalación PARI COMPACT2

Compresor PARI COMPACT2 (Tipo 152)

Nebulizador PARI LC PLUS® (Tipo 022)

Mascarilla pediátrica soft PARI (Tipo 041)

Importante: Antes de utilizar el producto lea detenidamente estas instrucciones de uso. Atención: respete todas las instrucciones y la información sobre seguridad.

Conserve las instrucciones de uso en buen estado.

